

ARNDALE5 CPU Board Schematics

Revision	Date	Description	Designed By
Rev 1.0	2012.05	WorkingSample Version	FELIX
Rev 1.1	2012.08	EvaluationSample Version	FELIX

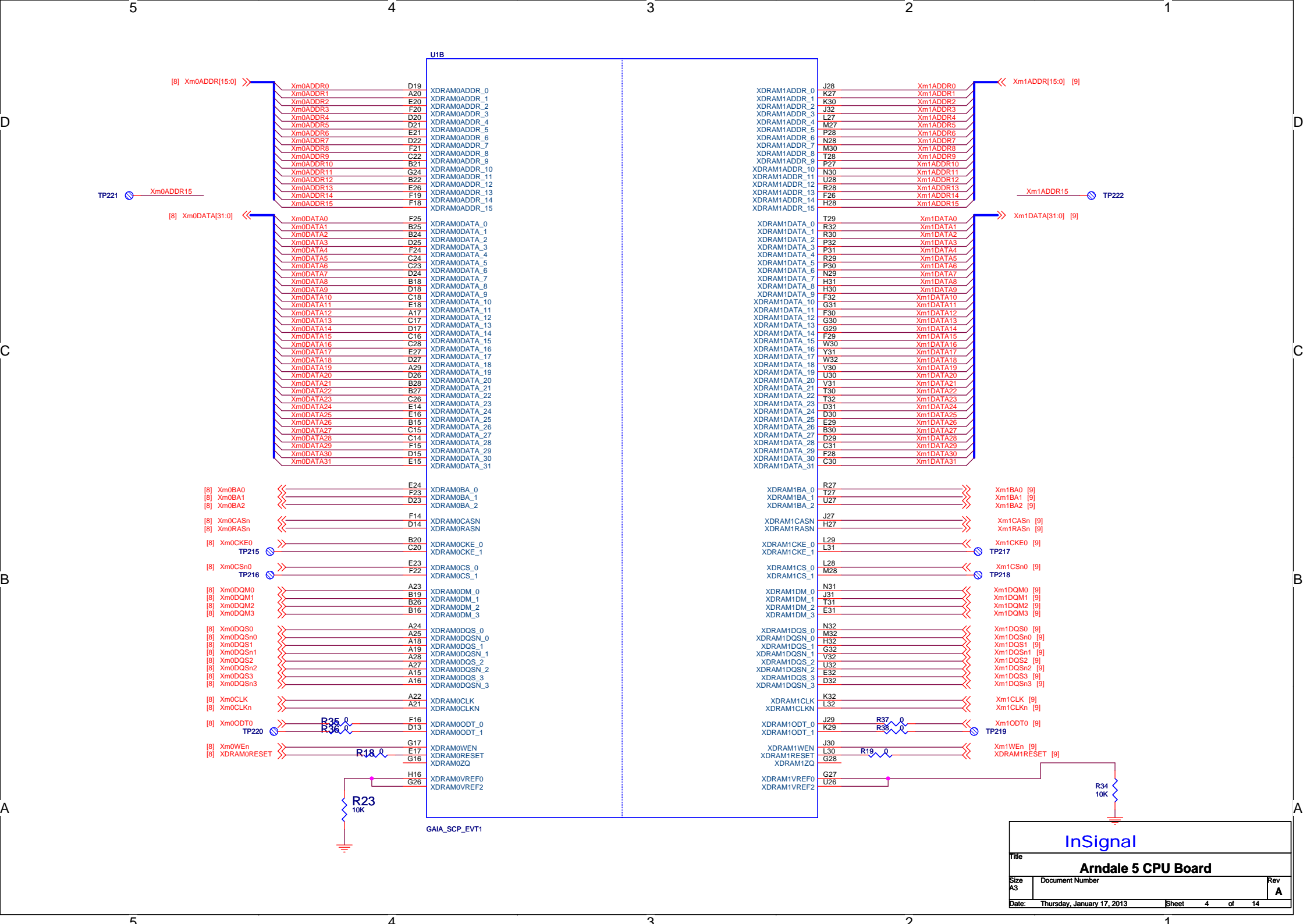

InSignal		
Arndale 5 CPU Board		
Size A4	Document Number Revision History	Rev 1.1
Date: Thursday, January 17, 2013	Sheet 1	of 14



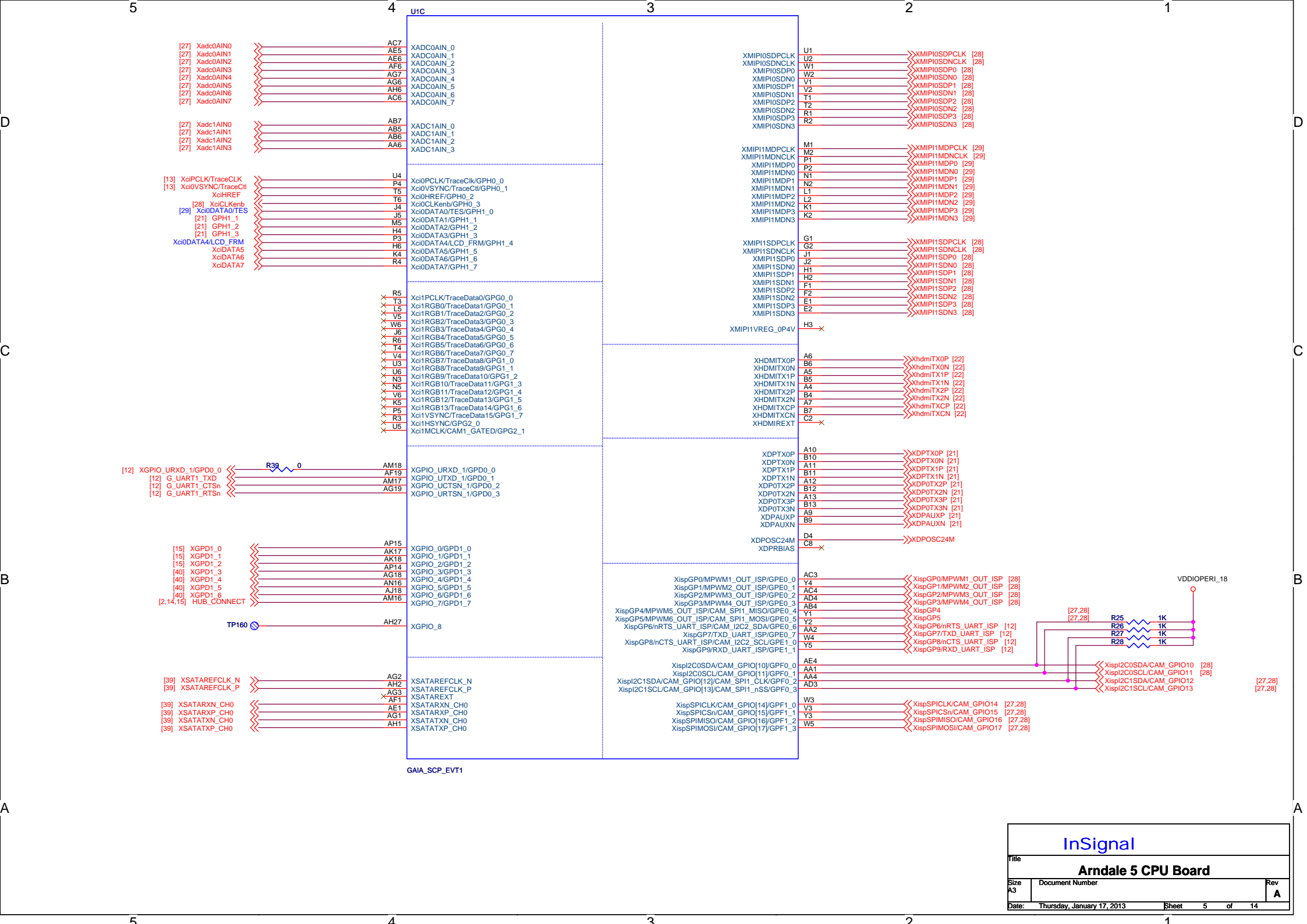

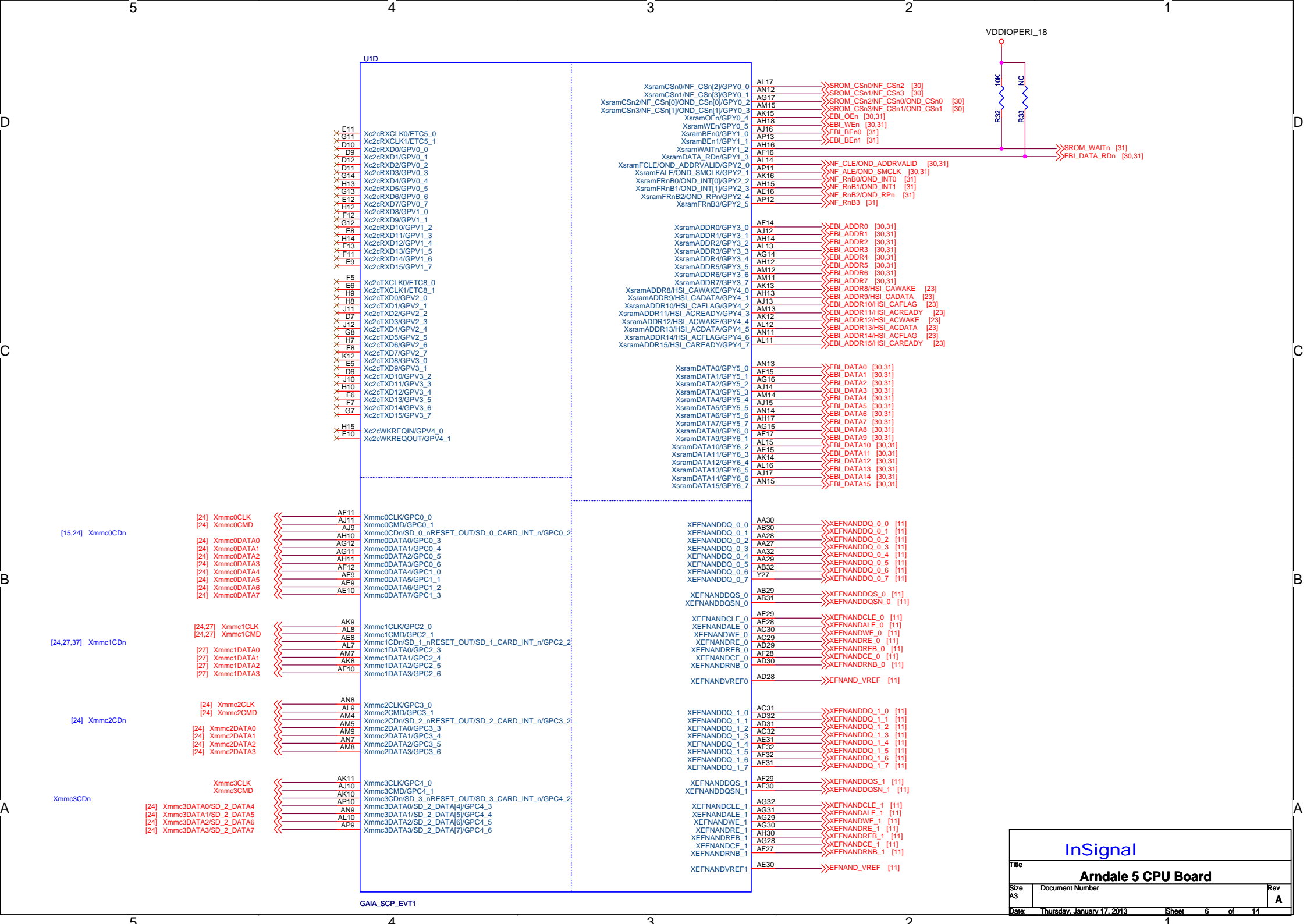

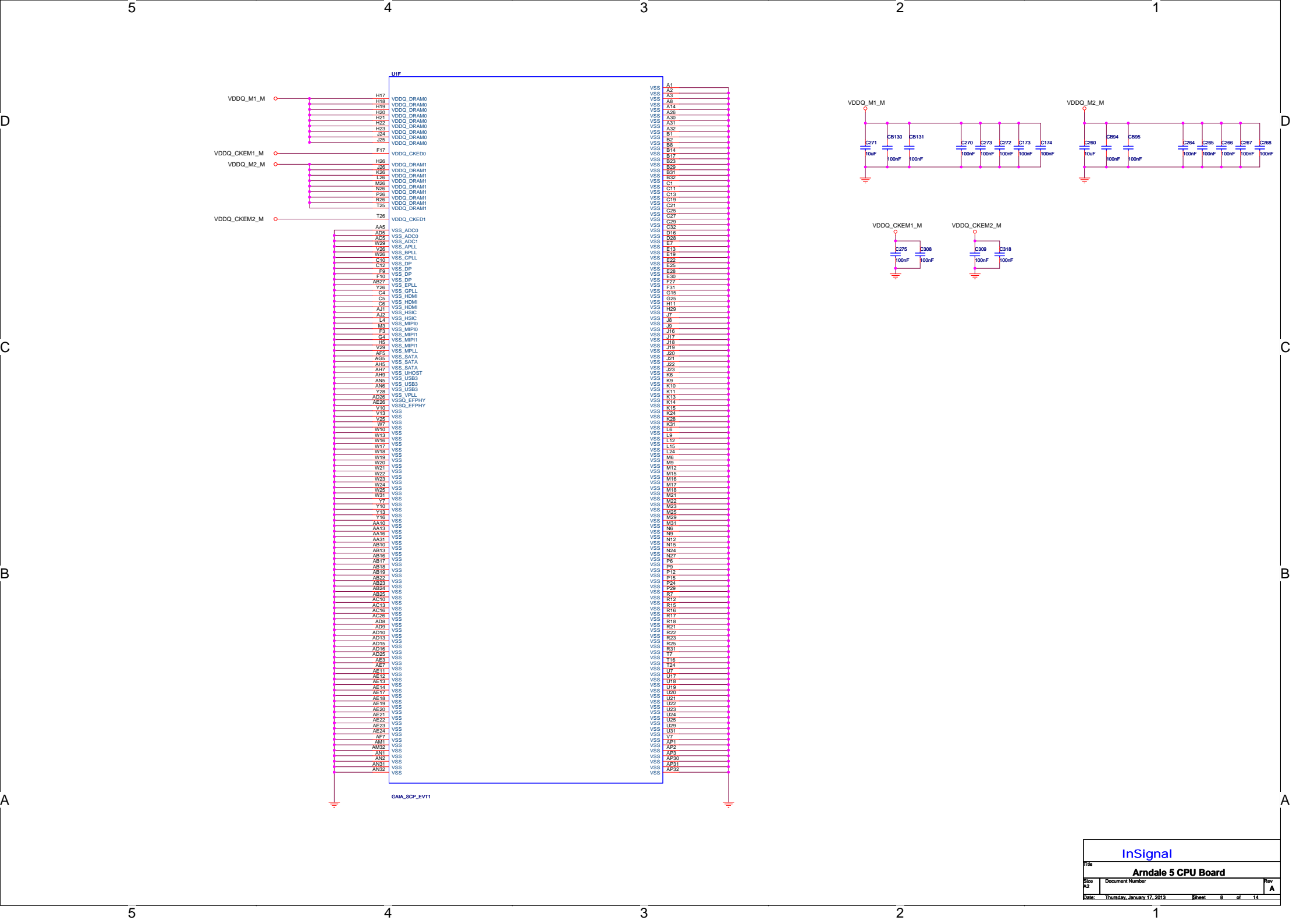

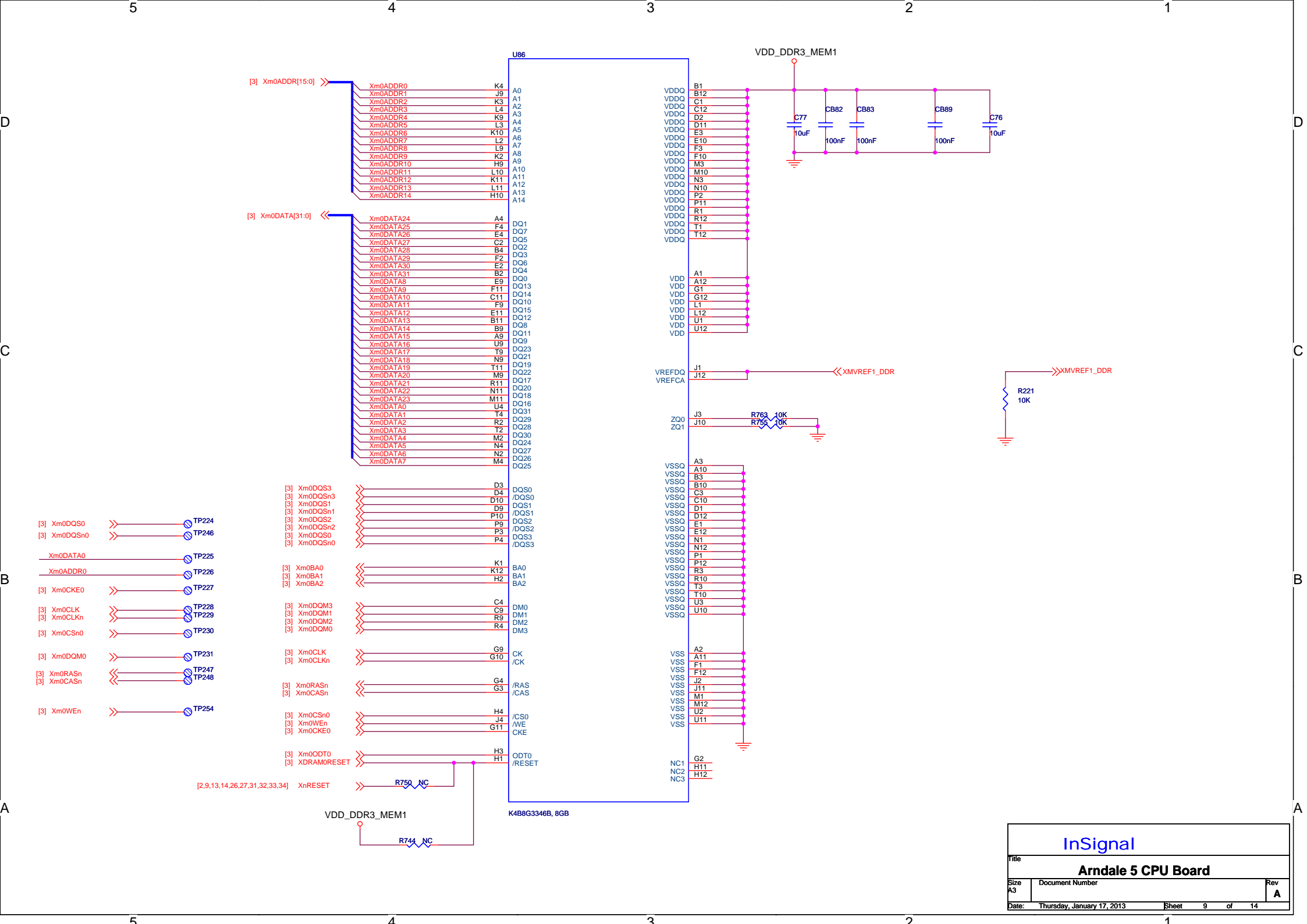

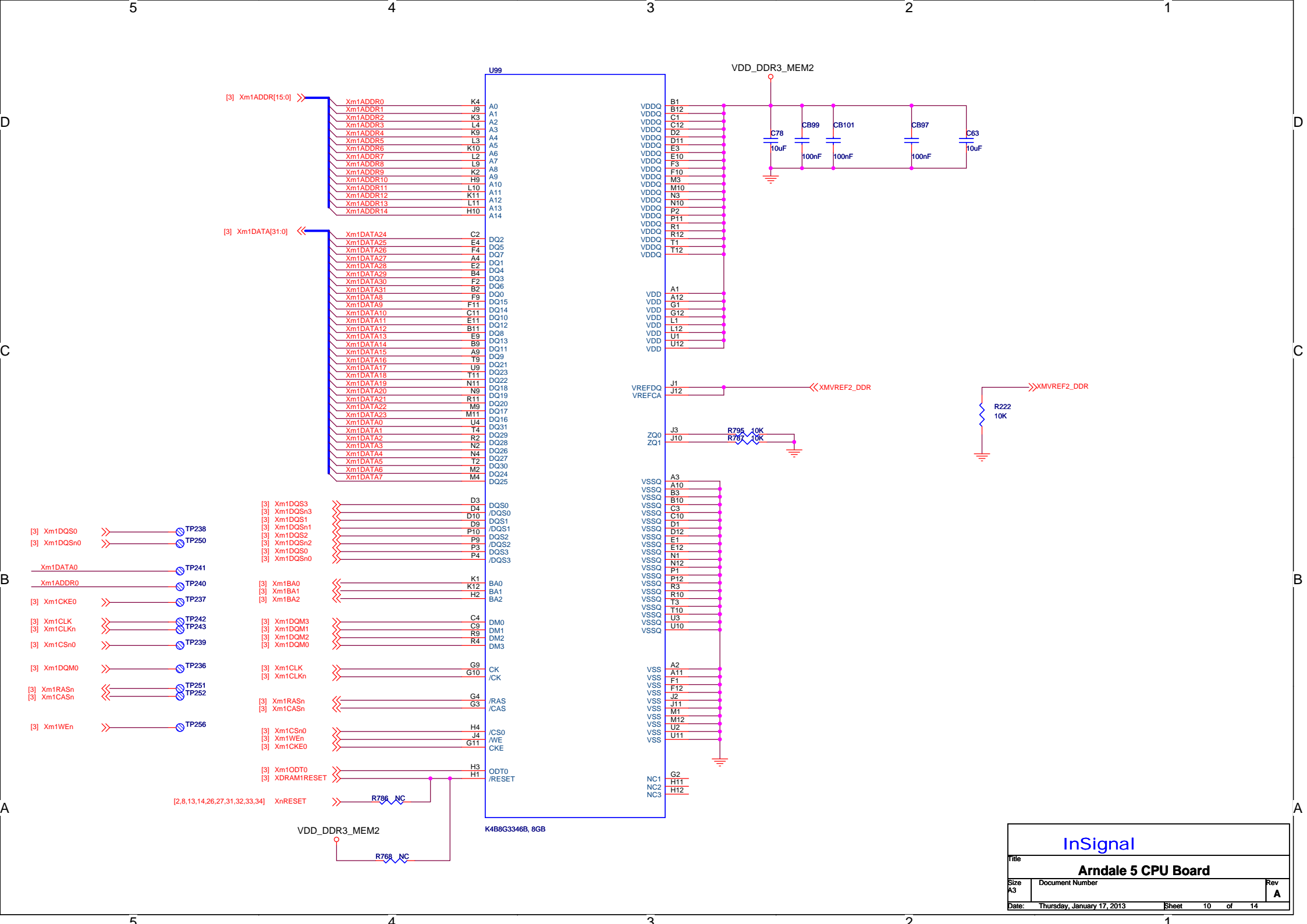

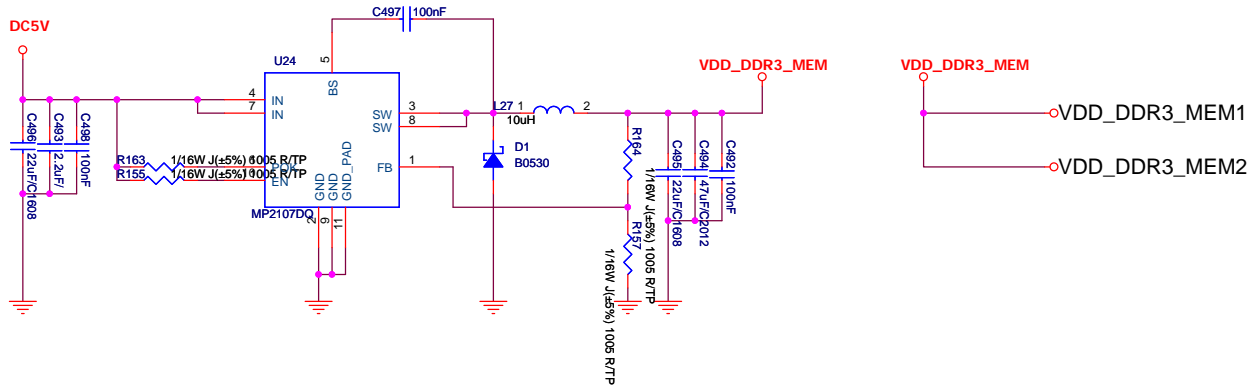

USB HUB

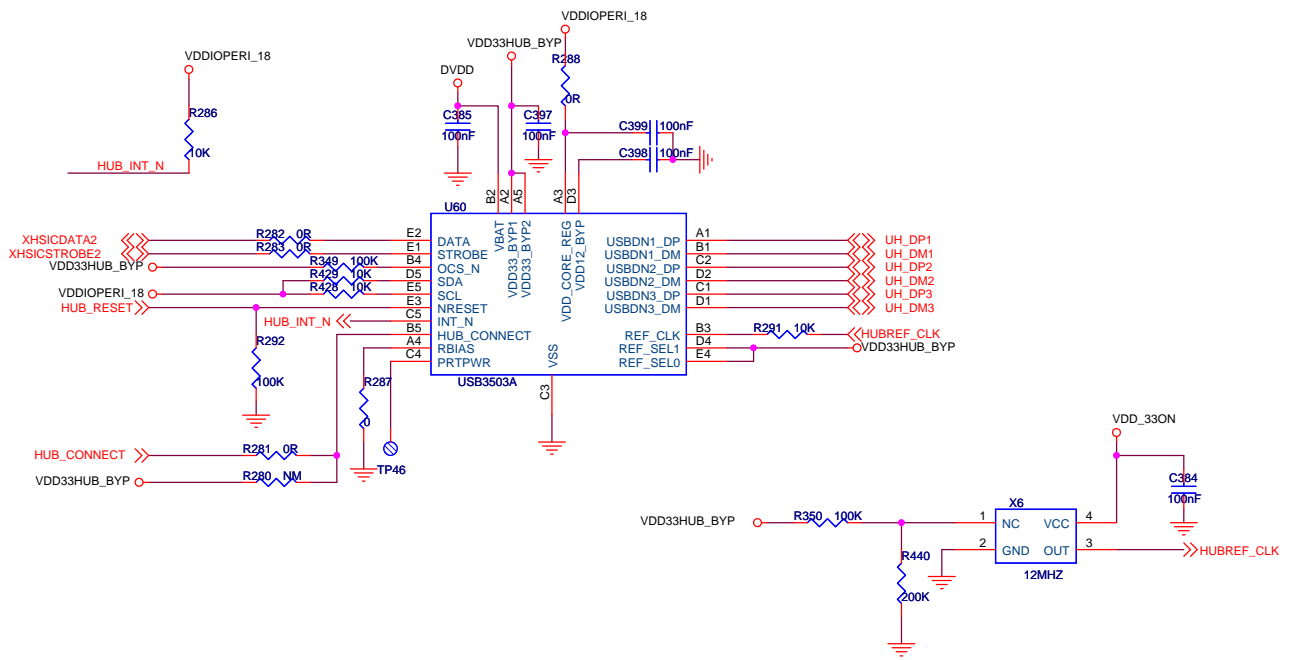

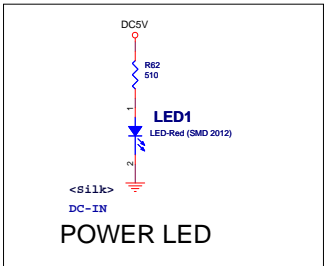
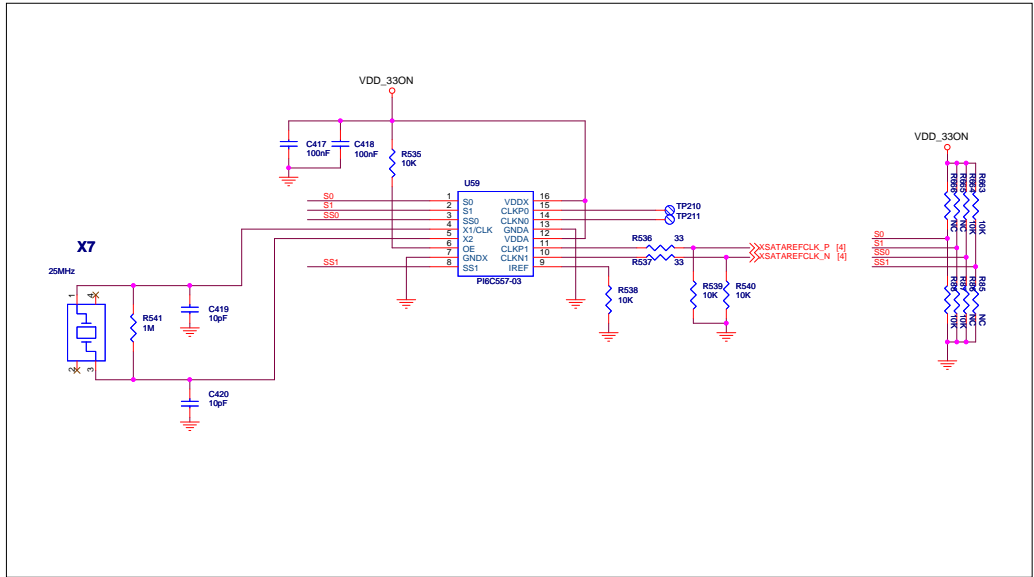
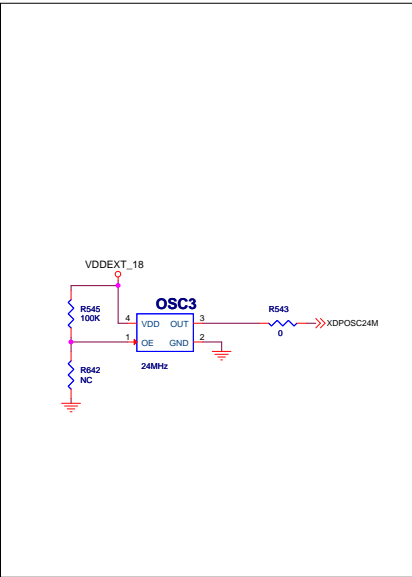
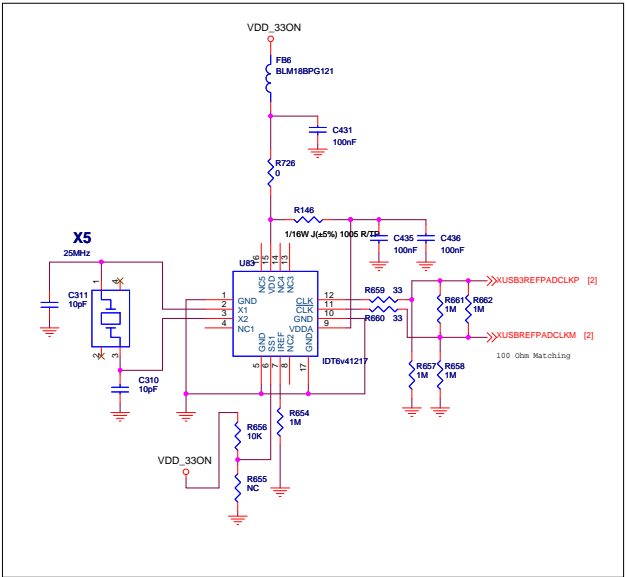
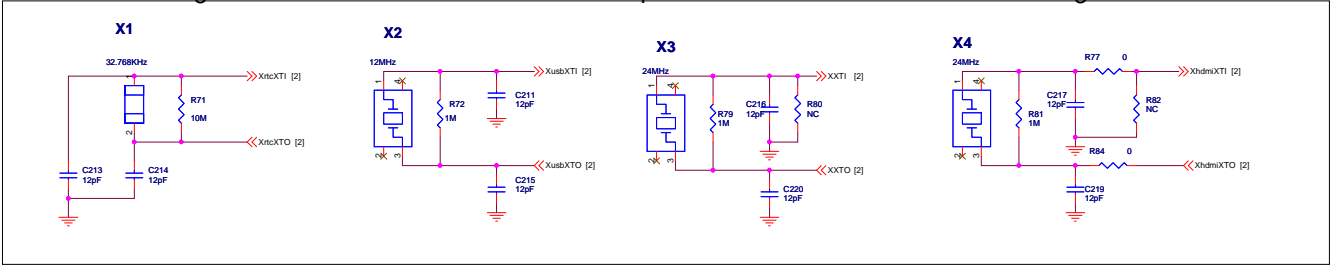

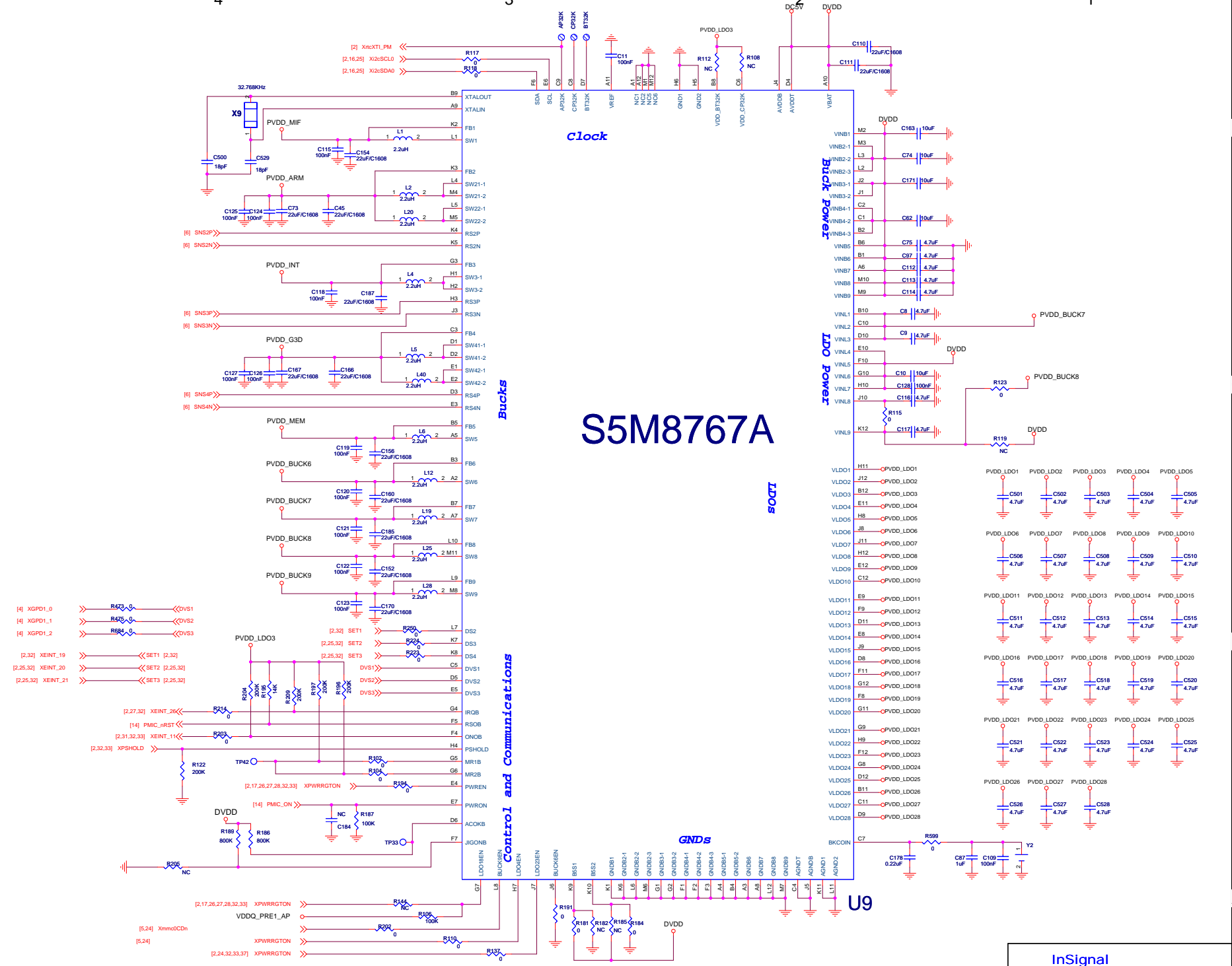

S5M8767A

InSignal		
Arndale 5 CPU Board		
File	Document Number	Rev
Size		A
Date: Thursday, January 17, 2013	Sheet	13 of 14

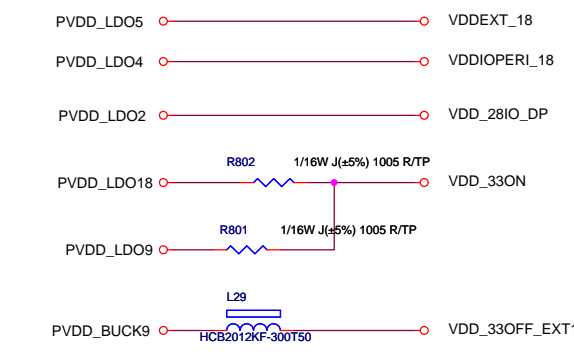
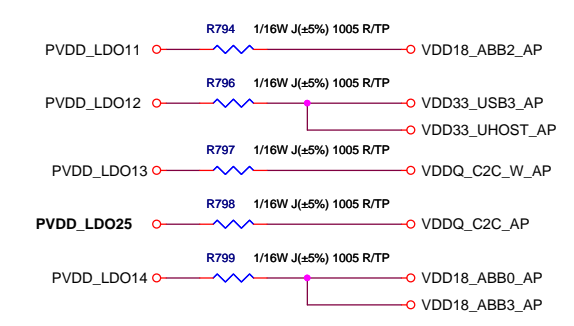
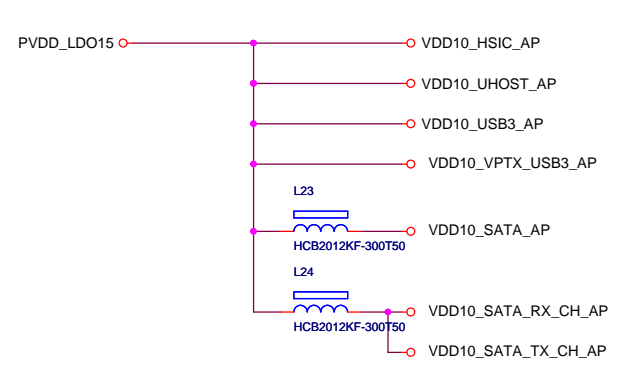
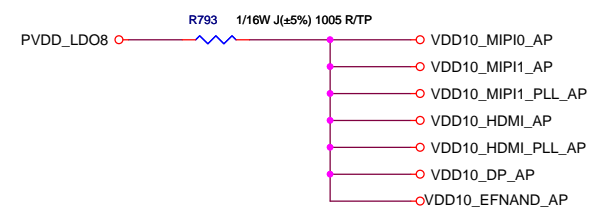
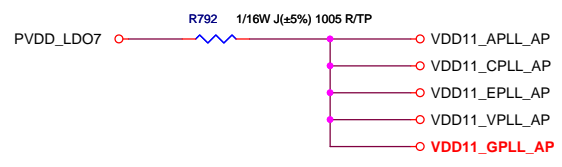
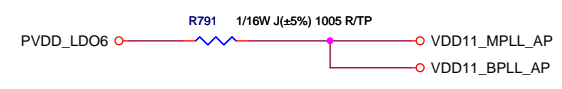
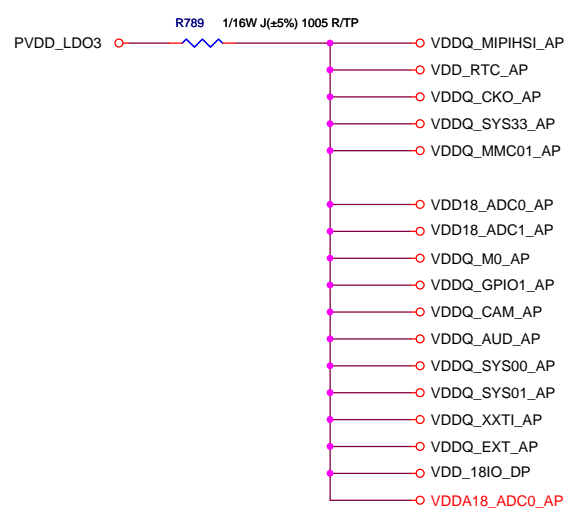
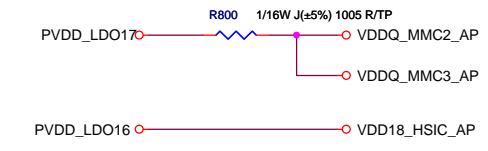
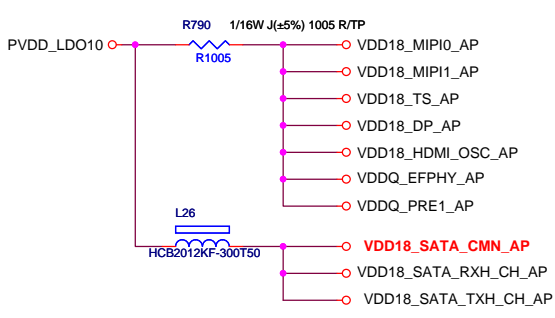
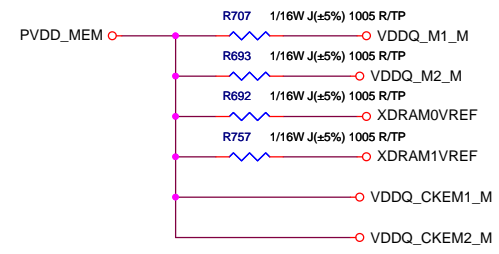

InSignal		
Arndale 5 CPU Board		
Size A3	Document Number	Rev A
Date: Thursday, January 17, 2013	Sheet 14	of 14